



Meters
Valves
Instruments
Systems

1800C and 1800C-HC Series Service Regulators



BUY NOW

Devtech Sales, Inc. is a Florida-based manufacturer's representative focused on supplying engineered equipment to natural gas, power and industrial customers. Devtech is Florida's leading provider of measurement and control products and systems such as gas meters, valves, odorizers, filters, instruments, flow correctors, flow computers, gauges, gate stations, meter/regulator skids and automatic meter reading systems.

Devtech Sales, Inc. • 118 S. Lake Ave. • Avon Park, FL • 863-453-5959

[HTTPS://WWW.DEVTECHSALES.COM](https://www.devtechsales.com)

1800C and 1800C-HC Series Service Regulators

Technical Bulletin

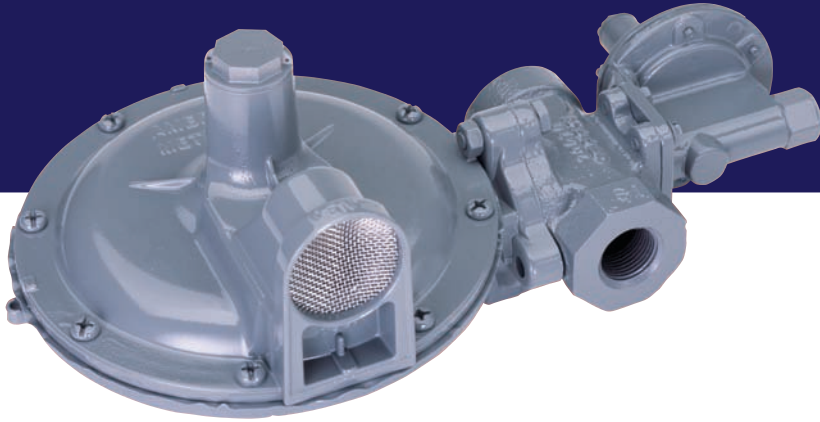

elster
American Meter

The 1800C Series pressure regulators are designed to control natural gas, air, nitrogen, carbon dioxide, propane vapor, and other non-corrosive gases in residential, light commercial, and small industrial applications.

General Information

Outlet pressures between 3.5" W.C. and 2 PSIG are available. Operating temperature range is -20°F to 150°F (-30°C to 65°C). Maximum flow rate is 2500 SCFH (70.8 m³/h).

All models conform to ANSI Code B109.4-1998, and CGA Service-Type Regulator Specification CAN/CGA-6.18-M95.

Features

- Variety of interchangeable orifices and spring ranges
- 90 Degree (Right Angle), 180 Degree (Straight-Flow), or Offset Valve Body (See photo below)
- Wide range of valve body connection sizes

Options

Vent Elbow

The regulator vent opening should face downward (6 o'clock) to minimize the chance of blockage from ice and snow. If not possible, a 3/4" NPT plastic, 90° vent elbow (part number 78041P025) and separate protective screen (part number 70400P017) may be screwed into the vent to provide the necessary protection.

Elevation Compensation

The E.C. orifice is recommended for installations where the inlet pressure may vary over a wide range. The E.C. orifice is available in two sizes: 1/8" x 3/16" and 3/16". The capacities of these orifices are the same as the standard orifice of the same size.

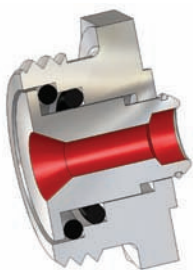

Full Capacity Relief Valve

Full capacity internal relief valve standard on all models. (See Performance Graphs on page 9)

Splashguards

UV stabilized, weather-resistant, resin device that protects the vent screen from

Applications

Model Number	Description
1813C	Basic regulator with full-capacity internal relief with 3/4" or 1" NPT vent.
1813C-HC	Basic regulator with full-capacity internal relief with 3/4" or 1" NPT vent.
1843C	Basic regulator with full-capacity internal relief and overpressure shut-off and 3/4" or 1" NPT vent.
1843C-HC	Basic regulator with full-capacity internal relief and overpressure shut-off and 3/4" or 1" NPT vent.
1853C w/ USSA	Basic regulator with full-capacity internal relief and overpressure, underpressure shut-off and 3/4" or 1" NPT vent.
1853C-HC w/ USSA	Basic regulator with full-capacity internal relief and overpressure, underpressure shut-off and 3/4" or 1" NPT vent.

splashes while providing a large external vent opening to keep regulators working properly.

Safety Shutoff Devices

Overpressure Shutoff (OPSO) — Operates independently. The OPSO will shut off the gas supply in the event of a serious downstream pressure build-up. These are available in two pressure ranges on the Models 1843C and 1843C-HC.

Spring Range	Part Number
14" W.C. to 35" W.C.	71403P005
1 PSIG to 3 1/2 PSIG	71403P004

When the outlet pressure exceeds the OPSO set point, the pressure under the OPSO diaphragm (A) compresses the pressure spring (B) forcing the diaphragm stem (E) upwards and releasing plunger (D). This permits the shut-off spring (F) to force the shut-off disc (G) against the back side of the special double-ended orifice.

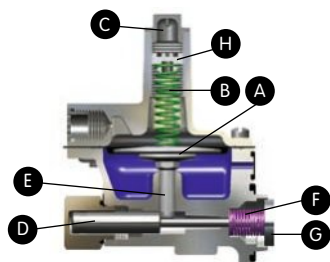

- | | |
|-------------------------------|--------------------------|
| A OPSO Diaphragm Plate | B Pressure Spring |
| C Cap | D Plunger |
| E Diaphragm Stem | F Shut-off Spring |
| G Shut-off Disc | H Adjusting Screw |

Universal Safety Shutoff Assembly (USSA) — USSA protects the downstream piping from both over- and under-pressure conditions by shutting off the gas flow at the inlet side of the regulator orifice. Both Over- and under-pressure shut-off set points are adjustable depending on spring ranges selected.

USSA Shutoff Spring Ranges

Over Pressure Spring Ranges

Spring Range	Part Number
7.5 - 24" W.C.	70017P123
20 - 32" W.C.	70017P124
24 - 44" W.C.	70017P125
40 - 84" W.C.	70017P126
3 - 5 PSIG	70017P127
4 - 7 PSIG	70017P128

Under Pressure Spring Ranges

Spring Range	Part Number
3 - 6" W.C.	70017P133
6 - 24" W.C.	70017P134
24 - 60" W.C.	70017P135

Pressure Taps

1/8" NPT taps are available on most valve heads.

Offset Valve Body



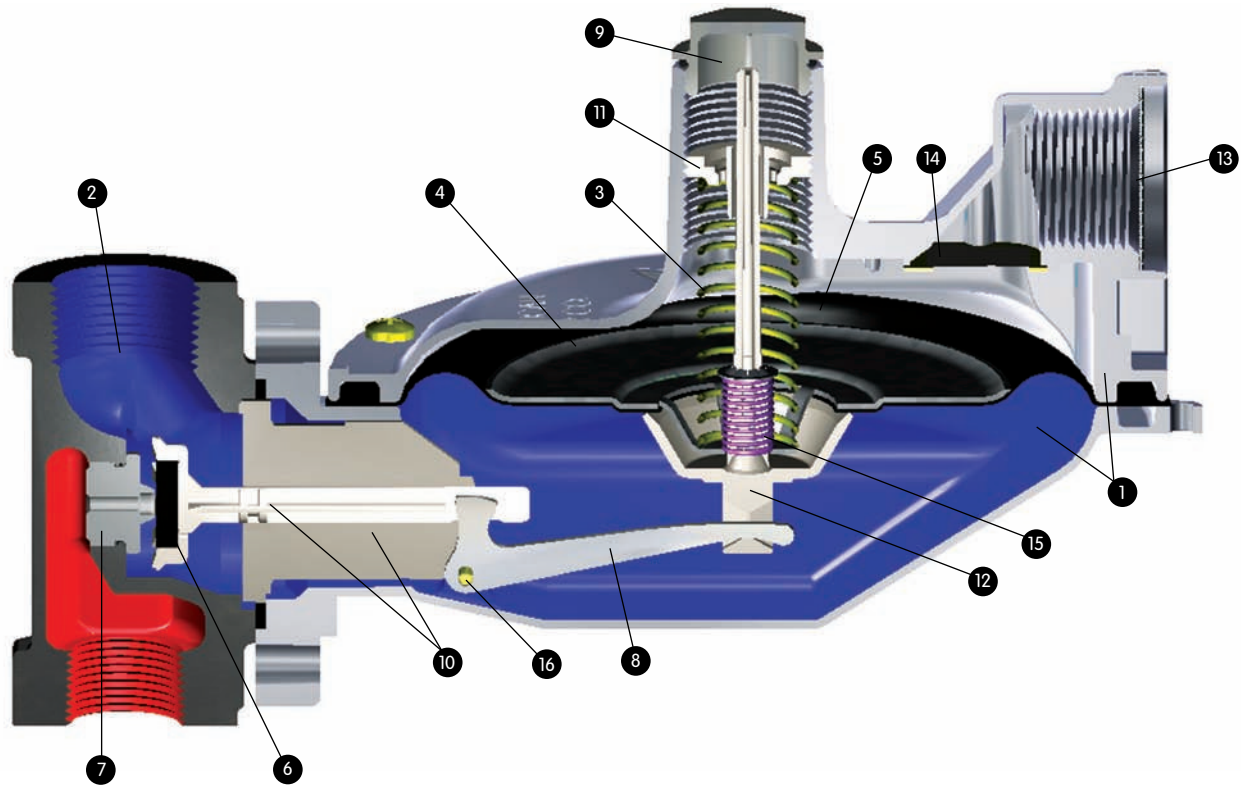

Material Specifications

- 1** Diaphragm Case - Precision die-cast aluminum with an exclusive seven-step advanced conversion coating, single-coat polyester primer and high solids polyurethane top coat.
- 2** Valve Body - Cast grey iron, undercoated, single coat polyester primer and high solids polyurethane top coat. NPT threads meet ANSI/ASME B1.20.1. BSP-TR threads meet BS EN 10226.

Available sizes: 3/4" x 3/4", 3/4" x 1", 3/4" x 1-1/4", 1" x 1", 1" x 1-1/4" and 1-1/4" x 1-1/4" NPT or BSP-TR

Offset valve body: 3/4" x 3/4", 3/4" x 1" and 1" x 1" NPT or BSP-TR

- 3** Pressure Spring - Steel, zinc plated and yellow chromate. Color coded for identification.

Outlet Pressure	Color Code	Part Number
3.5" to 6" W.C.	Blue	70017P043
3.5" to 7.5" W.C.	Tan	70017P089
5.5" to 8.5" W.C.	Yellow	70017P044
6" to 12" W.C.	Brown	70017P137
6" to 15" W.C.	Purple	70017P042
12" to 28" W.C.	White	70017P060
24" to 48" W.C.	Red	70017P082
42" W.C. to 2 PSIG	Red - Red	70017P049

- 4** Diaphragm Plate - Steel, Electrogalvanized.
- 5** Diaphragm - Buna N; Nylon fabric reinforced.
- 6** Seat Disc - Buna N; 60, 70 (std.) or 80 durometer rating.
- 7** Orifice Valve - High strength, corrosion resistant aluminum.

Orifice Size	Standard Part Number	Part Number with OPSO
9/16"	72494P026	72751P019
1/2"	72494P025	72751P016
3/8"	72494P023	72751P014
5/16"	72494P022	72751P013
1/4"	72494P021	72751P012
3/16"	72494P020	72751P011
1/8" x 3/16"	72494P030	72751P020
1/8"	72494P019	N/A

- 8** Lever - Stamped aluminum.
- 9** Seal Plug - Polyester thermoplastic UV stabilized.
- 10** Plunger Valve/Plunger Guide Minlon.

- 11** Pressure Adjustment Screw - Minlon.
- 12** Relief Valve Stem - Minlon.
- 13** Vent Screen - Stainless Steel
All models are designed with a removable weather and bug-proof stainless steel screen to resist freeze-ups and to exclude foreign matter. The vent is threaded 3/4" or 1" NPT (BSP-TR threads available). Inside installation requires a vent line of sufficient diameter to carry gas vented by the regulator to a safe outside location away from any opening(s) in the structure. Comply with applicable Federal, State and local codes.
- 14** Vent Valve - Stainless Steel with Electrogalvanized steel retainer.
- 15** Relief Valve Spring - Steel, zinc plated and yellow chromate. Color coded for identification. Non-adjustable, standard set point of 8" w.c. above outlet set pressure of 7" w.c. Standard set point of 1.3 PSIG above outlet set pressure of 2 PSIG.
- 16** Lever Pin - Carbon steel, zinc plated and yellow chromate.

1800C Series Regulator Capacity Performance

3/4" Outlet

Set Point 7.0" W.C. (17.4 mbar)
at 50 SCFH

SCFH (m³/h) 0.60 specific gravity gas at
60°F and 14.7 PSIA (20°C and 1.01 bar).

Pressure spring 70017P044. Outlet
pressure variance not to exceed +2" -1" W.C.
from set point, horizontal position.

1800C Series Regulator Capacity SCFH (m³/h)

Inlet PSIG (bar)	1/8" x 3/16" Orifice	3/16" Orifice	1/4" Orifice	5/16" Orifice	3/8" Orifice	1/2" Orifice	9/16" Orifice
1 (0.07)	—	175 (5.0)	250 (7.1)	325 (9.2)	350 (9.9)	400 (11.3)	400 (11.3)
2 (0.14)	—	300 (8.5)	425 (12.0)	475 (13.5)	550 (15.6)	650 (18.4)	650 (18.4)
3 (0.21)	—	375 (10.6)	500 (14.2)	600 (17.0)	700 (19.8)	800 (22.7)	800 (22.7)
5 (0.34)	275 (7.8)	500 (14.2)	700 (19.8)	800 (22.7)	950 (26.9)	1000 (28.3)	1200 (34.0)
10 (0.70)	375 (10.6)	750 (21.2)	1100 (31.2)	1200 (34.0)	1400 (39.6)	1500 (42.5)	1700 (48.1)
15 (1.00)	450 (12.7)	950 (26.9)	1400 (39.6)	1500 (42.5)	1600 (45.3)	1900 (53.8)	2000 (56.6)
20 (1.40)	500 (14.2)	1100 (31.2)	1700 (48.1)	1700 (48.1)	1900 (53.8)	2200 (62.3)	2300 (65.1)
30 (2.10)	700 (19.8)	1400 (39.6)	2000 (56.6)	2200 (62.3)	2400 (68.0)	2500 (70.8)	—
40 (2.80)	800 (22.7)	1700 (48.1)	2400 (68.0)	2500 (70.8)	2500 (70.8)	—	—
60 (4.10)	1100 (31.2)	2300 (65.1)	2500 (70.8)	2500 (70.8)	—	—	—
100 (6.90)	1700 (48.1)	2500 (70.8)	2500 (70.8)	—	—	—	—
125 (8.60)	2100 (59.5)	—	—	—	—	—	—

For optimum performance, maximum inlet pressure should not exceed maximum capacity rating for any given orifice size.

1" Outlet

Set Point 7.0" W.C. (17.4 mbar)
at 50 SCFH

SCFH (m³/h) 0.60 specific gravity gas at
60°F and 14.7 PSIA (20°C and 1.01 bar).

Pressure spring 70017P044. Outlet
pressure variance not to exceed +2" -1" W.C.
from set point, horizontal position.

1800C Series Regulator Capacity SCFH (m³/h)

Inlet PSIG (bar)	1/8" x 3/16" Orifice	3/16" Orifice	1/4" Orifice	5/16" Orifice	3/8" Orifice	1/2" Orifice	9/16" Orifice
1 (0.07)	—	175 (5.0)	250 (7.1)	300 (8.5)	375 (10.6)	475 (13.5)	500 (14.2)
2 (0.14)	—	250 (7.1)	350 (9.9)	450 (12.7)	500 (14.2)	600 (17.0)	650 (18.4)
3 (0.21)	—	300 (8.5)	450 (12.7)	550 (15.6)	700 (19.8)	850 (24.1)	950 (26.9)
5 (0.34)	250 (7.1)	450 (12.7)	650 (18.4)	750 (21.2)	950 (26.9)	1200 (34.0)	1300 (36.8)
10 (0.70)	350 (9.9)	700 (19.8)	1000 (28.3)	1400 (39.6)	1600 (45.3)	1900 (53.8)	2000 (56.6)
15 (1.00)	425 (12.0)	900 (25.5)	1400 (39.6)	1900 (53.8)	2100 (59.5)	2500 (70.8)	2500 (70.8)
20 (1.40)	500 (14.2)	1100 (31.2)	1700 (48.1)	2300 (65.1)	2500 (70.8)	2500 (70.8)	—
30 (2.10)	600 (17.0)	1400 (39.6)	2300 (65.1)	2500 (70.8)	2500 (70.8)	—	—
40 (2.80)	750 (21.2)	1700 (48.1)	2500 (70.8)	2500 (70.8)	—	—	—
60 (4.10)	1000 (28.3)	2400 (68.0)	2500 (70.8)	—	—	—	—
100 (6.90)	1600 (45.3)	2500 (70.8)	—	—	—	—	—
125 (8.60)	2000 (56.6)	—	—	—	—	—	—

For optimum performance, maximum inlet pressure should not exceed maximum capacity rating for any given orifice size.

1800C Series Regulator Capacity Performance

1-1/4" Outlet

Set Point 7.0" W.C. (17.4 mbar)
at 50 SCFH

SCFH (m³/h) 0.60 specific gravity gas at
60°F and 14.7 PSIA (20°C and 1.01 bar).

Pressure spring 70017P044. Outlet
pressure variance not to exceed +2" -1" W.C.
from set point, horizontal position.

1800C Series Regulator Capacity SCFH (m³/h)

Inlet PSIG (bar)	1/8" x 3/16" Orifice	3/16" Orifice	1/4" Orifice	5/16" Orifice	3/8" Orifice	1/2" Orifice	9/16" Orifice
1 (0.07)	—	200 (5.7)	325 (9.2)	350 (9.9)	375 (10.6)	475 (13.5)	500 (14.2)
2 (0.14)	—	325 (9.2)	500 (14.2)	600 (17.0)	700 (19.8)	950 (26.9)	1400 (39.6)
3 (0.21)	—	425 (12.0)	650 (18.4)	950 (26.9)	1200 (34.0)	1700 (48.1)	1900 (53.8)
5 (0.34)	275 (7.8)	550 (15.6)	1000 (28.3)	1600 (45.3)	2100 (59.5)	2500 (70.8)	2500 (70.8)
10 (0.70)	375 (10.6)	850 (24.1)	1500 (42.5)	2400 (68.0)	2500 (70.8)	2500 (70.8)	2500 (70.8)
15 (1.00)	450 (12.7)	1000 (28.3)	1800 (51.0)	2500 (70.8)	—	—	—
20 (1.40)	550 (15.6)	1200 (34.0)	2100 (59.5)	—	—	—	—
30 (2.10)	700 (19.8)	1600 (45.3)	—	—	—	—	—
40 (2.80)	800 (22.7)	—	—	—	—	—	—
60 (4.10)	1100 (31.2)	—	—	—	—	—	—
100 (6.90)	1400 (39.6)	—	—	—	—	—	—

For optimum performance, maximum inlet pressure should not exceed maximum capacity rating for any given orifice size.

3/4" Outlet

Set Point 2 PSIG (0.14 bar)
at 50 SCFH

SCFH (m³/h) 0.60 specific gravity gas at
60°F and 14.7 PSIA (20°C and 1.01 bar).

Pressure spring 70017P049. Outlet
pressure variance not to exceed +/- 10%
from set point, horizontal position.

1800C Series Regulator Capacity SCFH (m³/h)

Inlet PSIG (bar)	1/8" x 3/16" Orifice	3/16" Orifice	1/4" Orifice	5/16" Orifice	3/8" Orifice	1/2" Orifice	9/16" Orifice
3 (0.21)	150 (4.2)	175 (5.0)	300 (8.5)	325 (9.2)	375 (10.6)	400 (11.3)	500 (14.2)
5 (0.34)	250 (7.1)	325 (9.2)	450 (12.7)	525 (14.9)	575 (16.3)	700 (19.8)	750 (21.2)
10 (0.70)	375 (10.6)	550 (15.6)	700 (19.8)	825 (23.4)	1000 (28.3)	1200 (34.0)	1300 (36.8)
15 (1.00)	450 (12.7)	750 (21.2)	900 (25.5)	1100 (31.2)	1300 (36.8)	1500 (42.5)	1800 (51.0)
20 (1.40)	550 (15.6)	900 (25.5)	1200 (34.0)	1300 (36.8)	1600 (45.3)	1900 (53.8)	—
30 (2.10)	700 (19.8)	1200 (34.0)	1500 (42.5)	1800 (51.0)	2100 (59.5)	—	—
40 (2.80)	850 (24.1)	1500 (42.5)	2000 (56.6)	2200 (62.3)	—	—	—
60 (4.10)	1100 (31.2)	2100 (59.5)	2500 (70.8)	—	—	—	—
100 (6.90)	1700 (48.1)	2500 (70.8)	—	—	—	—	—
125 (8.60)	2100 (59.5)	—	—	—	—	—	—

For optimum performance, maximum inlet pressure should not exceed maximum capacity rating for any given orifice size.

1800C Series Regulator Capacity Performance

1" Outlet

Set Point 2 PSIG (0.14 bar)
at 50 SCFH

SCFH (m³/h) 0.60 specific gravity gas at
60°F and 14.7 PSIA (20°C and 1.01 bar).

Pressure spring 70017P049. Outlet
pressure variance not to exceed +/- 10%
from set point, horizontal position.

1800C Series Regulator Capacity SCFH (m³/h)

Inlet PSIG (bar)	1/8" x 3/16" Orifice	3/16" Orifice	1/4" Orifice	5/16" Orifice	3/8" Orifice	1/2" Orifice	9/16" Orifice
3 (0.21)	150 (4.2)	225 (6.4)	250 (7.1)	350 (9.9)	425 (12.0)	550 (15.6)	550 (15.6)
5 (0.34)	225 (6.4)	350 (9.9)	450 (12.7)	500 (14.2)	650 (18.4)	750 (21.2)	900 (25.5)
10 (0.70)	350 (9.9)	600 (17.0)	750 (21.2)	850 (24.1)	1000 (28.3)	1300 (36.8)	1500 (42.5)
15 (1.00)	425 (12.0)	800 (22.7)	1000 (28.3)	1100 (31.2)	1400 (39.6)	1700 (48.1)	2000 (56.6)
20 (1.40)	500 (14.2)	1000 (28.3)	1200 (34.0)	1400 (39.6)	1800 (51.0)	2100 (59.5)	—
30 (2.10)	650 (18.4)	1300 (36.8)	1700 (48.1)	2000 (56.6)	2500 (70.8)	—	—
40 (2.80)	800 (22.7)	1700 (48.1)	2200 (62.3)	2500 (70.8)	—	—	—
60 (4.10)	1100 (31.2)	2500 (70.8)	2500 (70.8)	—	—	—	—
100 (6.90)	1700 (48.1)	2500 (70.8)	—	—	—	—	—
125 (8.60)	2100 (59.5)	—	—	—	—	—	—

For optimum performance, maximum inlet pressure should not exceed maximum capacity rating for any given orifice size.

1-1/4" Outlet

Set Point 2 PSIG (0.14 bar)
at 50 SCFH

SCFH (m³/h) 0.60 specific gravity gas at
60°F and 14.7 PSIA (20°C and 1.01 bar).

Pressure spring 70017P049. Outlet
pressure variance not to exceed +/- 10%
from set point, horizontal position.

1800C Series Regulator Capacity SCFH (m³/h)

Inlet PSIG (bar)	1/8" x 3/16" Orifice	3/16" Orifice	1/4" Orifice	5/16" Orifice	3/8" Orifice	1/2" Orifice	9/16" Orifice
3 (0.21)	150 (4.2)	225 (6.4)	350 (9.9)	375 (10.6)	425 (12.0)	550 (15.6)	550 (15.6)
5 (0.34)	225 (6.4)	350 (9.9)	500 (14.2)	600 (17.0)	700 (19.8)	900 (25.5)	1100 (31.2)
10 (0.70)	350 (9.9)	600 (17.0)	850 (24.1)	1100 (31.2)	1200 (34.0)	1700 (48.1)	2200 (62.3)
15 (1.00)	425 (12.0)	850 (24.1)	1200 (34.0)	1600 (45.3)	1900 (53.8)	2500 (70.8)	2500 (70.8)
20 (1.40)	500 (14.2)	1000 (28.3)	1700 (48.1)	2200 (62.3)	2500 (70.8)	2500 (70.8)	—
30 (2.10)	650 (18.4)	1500 (42.5)	2500 (70.8)	2500 (70.8)	2500 (70.8)	—	—
40 (2.80)	800 (22.7)	1900 (53.8)	2500 (70.8)	2500 (70.8)	—	—	—
60 (4.10)	1100 (31.2)	2500 (70.8)	2500 (70.8)	—	—	—	—
100 (6.90)	1700 (48.1)	2500 (70.8)	—	—	—	—	—
125 (8.60)	2100 (59.5)	—	—	—	—	—	—

For optimum performance, maximum inlet pressure should not exceed maximum capacity rating for any given orifice size.

1800C-HC Series Regulators

Ideal for light commercial and industrial use, the 1-1/4" 1800C-HC Series regulator is designed to increase output capacity during medium to high inlet pressure operations.

General Information

The 1800C-HC Series regulator's lightweight design features high-capacity capabilities for 1-1/4" NPT connections and flow capacities up to 4900 SCFH depending on inlet pressure and orifice selection. It complements the 1800C Series family of regulators.



AC-630 Meter with 1813C-HC Regulator

1800C-HC Series Regulator Capacity Performance

1-1/4" Outlet

Set Point 7.0" W.C. (17.4 mbar)
at 50 SCFH

SCFH (m³/h) 0.60 specific gravity gas at 60°F and 14.7 PSIA (20°C and 1.01 bar). Pressure spring 70017P044. Outlet pressure variance not to exceed +2" -1" W.C. from set point, horizontal position.

1800C Series Regulator Capacity SCFH (m³/h)

Inlet PSIG (bar)	1/8" x 3/16" Orifice	3/16" Orifice	1/4" Orifice	5/16" Orifice	3/8" Orifice	1/2" Orifice	9/16" Orifice
1 (0.07)	—	175 (5.0)	200 (5.7)	250 (7.1)	350 (9.9)	475 (13.5)	525 (14.9)
2 (0.14)	—	275 (7.8)	350 (9.9)	450 (12.7)	525 (14.9)	675 (19.1)	800 (22.7)
3 (0.21)	—	350 (9.9)	450 (12.7)	600 (17.0)	750 (21.2)	800 (22.7)	1100 (31.2)
5 (0.34)	275 (7.8)	450 (12.7)	700 (19.8)	850 (24.1)	1000 (28.3)	1500 (42.5)	1600 (45.3)
10 (0.70)	350 (9.9)	600 (17.0)	1100 (31.2)	1500 (42.5)	1600 (45.3)	2500 (70.8)	2700 (76.5)
15 (1.00)	425 (12.0)	950 (26.9)	1300 (36.8)	2300 (65.1)	2600 (73.6)	3300 (93.5)	3300 (93.5)
20 (1.40)	475 (13.5)	1100 (31.2)	1900 (53.8)	2900 (82.1)	3400 (96.3)	4200 (118.9)	3900 (110.4)
30 (2.10)	600 (17.0)	1500 (42.5)	2500 (70.8)	4000 (113.3)	4600 (130.3)	4900 (138.8)	—
40 (2.80)	750 (21.2)	1800 (51.0)	3200 (90.6)	4900 (138.8)	4900 (138.8)	—	—
60 (4.10)	1100 (31.2)	2500 (70.8)	4400 (124.6)	4900 (138.8)	—	—	—
100 (6.90)	1600 (45.3)	3800 (107.6)	—	—	—	—	—
125 (8.60)	2000 (56.6)	—	—	—	—	—	—

For optimum performance, maximum inlet pressure should not exceed maximum capacity rating for any given orifice size.

1800C and 1800C-HC Series Service Regulators - Other Technical Data

Full-Open Regulator Relief Capacity

For sizing downstream relief valves, use the following formulas to determine the regulator full-open capacity:

Critical flow rates Sub-critical flows

$$Q = 0.5 C \times \frac{P_1}{\sqrt{G}} \quad Q = C \times \frac{\sqrt{P_2 h}}{\sqrt{G}}$$

Critical flow occurs when the absolute outlet pressure is less than about 1/2 of the absolute inlet pressure.

- Q Maximum capacity of regulator
- C Orifice constant (see table below)
- P_1 Inlet absolute pressure (PSIA)
- P_2 Outlet absolute pressure (PSIA)
- h Differential pressure
- G Specific gravity of gas

Orifice Constants

Orifice	C
1/8"	25
1/8" x 3/16"	25
3/16"	57
1/4"	98
5/16"	149
3/8"	208
1/2"	353
9/16"	421

Maximum Recommended Inlet Pressure

Orifice Size	Inlet Pressure (PSIG)
9/16"	20
1/2"	50
3/8"	70
5/16"	125
1/4"	125
3/16"	125
1/8" x 3/16"	125
1/8"	125

This is the maximum inlet the regulator should operate at to insure complete lockup at no-flow conditions.

Other Gas Capacities

To determine the capacity of these regulators for gases other than natural gas, multiply the values within the capacity tables by a Specific Gravity Conversion Factor (F_g). The table below lists this factor for some of the more common gases.

Gas Type	Specific Gravity	Conversion Factor (F_g)
Air	1.00	0.77
Butane	2.01	0.55
Carbon Dioxide	1.52	0.63
Nitrogen	0.97	0.79
Propane	1.53	0.63

To calculate the Conversion Factor for other gases:

$$(F_g) = \sqrt{\frac{\text{Specific gravity of gas on which the capacity table is based}}{\text{Specific gravity of gas being used}}}$$

Example: If using propane and only having tables based on natural gas, the Specific Gravity Conversion Factor is :

$$(F_g) = \sqrt{\frac{\text{Specific gravity of natural gas (0.6)}}{\text{Specific gravity of propane (1.53)}}}$$

$$(F_g) = \sqrt{\frac{0.60}{1.53}}$$

$$(F_g) = 0.626$$

Regulator Pressure Rating

125 PSIG (8.6 bar) = Maximum recommended inlet pressure for normal service. Maximum recommended pressure may vary with orifice size.

175 PSIG (12 bar) = Maximum inlet pressure for abnormal or emergency service, without causing damage to regulator case.

2 PSIG (138 mbar) = Maximum outlet pressure for normal service.

10 PSIG (689 mbar) = Maximum outlet pressure which can be contained by pressure carrying components (no flange leakage to atmosphere except for normal relief action). **If regulator is subjected to these conditions, it should be removed from service.**

50 PSIG (3.5 bar) = Maximum outlet pressure for abnormal service without damage to internal components. **If regulator is subjected to these conditions, it should be removed from service.**

1800C and 1800C-HC Series Service Regulators

Regulator Relief Valve Performance

There are several methods of measuring the relief performance of a regulator. The worst case scenario will occur when the lever is disconnected. The data presented in the tables below represent this condition.

Outlet Pressure Relative to Inlet Pressure

3/4" Screened Vent – No Vent Pipe Set Pressure 7" W.C.

Outlet Pressure - Inches W.C. (mbar)

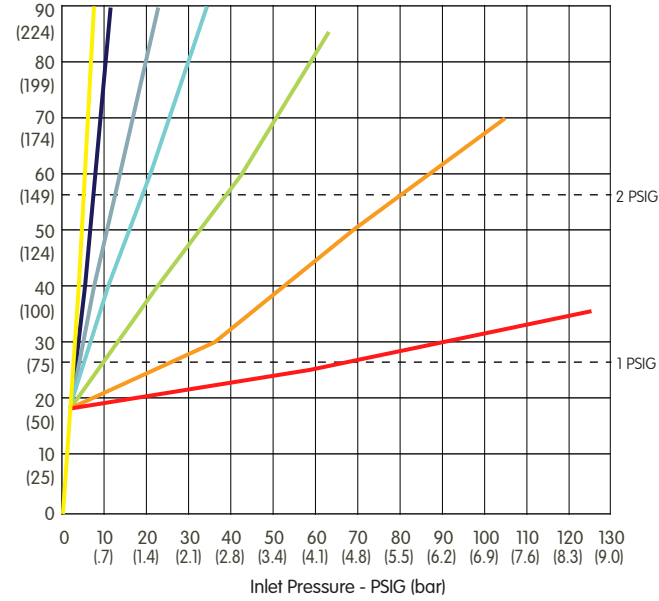

1" Screened Vent – No Vent Pipe Set Pressure 7" W.C.

Outlet Pressure - Inches W.C. (mbar)

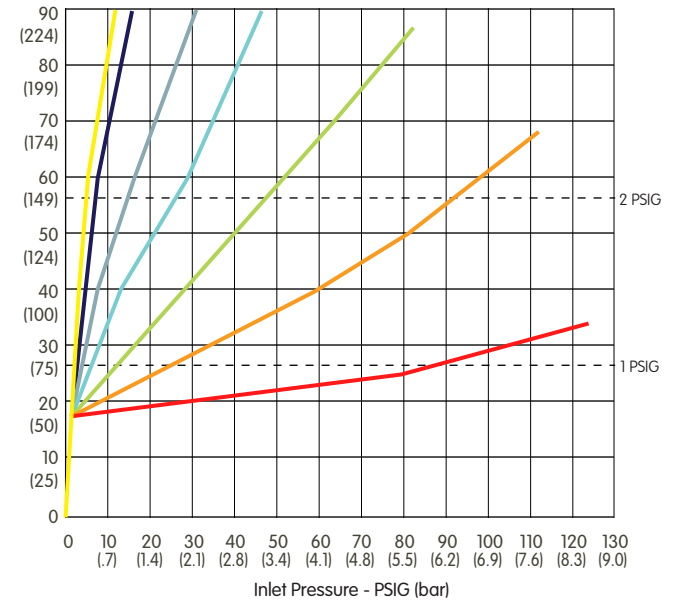

3/4" Screened Vent – No Vent Pipe Set Pressure 2 PSIG

Outlet Pressure - PSIG (bar)

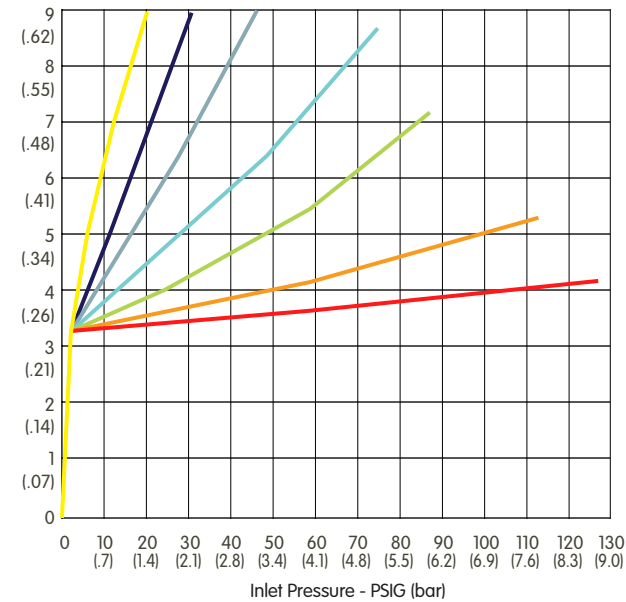

1" Screened Vent – No Vent Pipe Set Pressure 2 PSIG

Outlet Pressure - PSIG (bar)

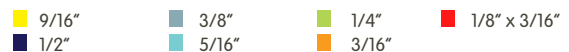
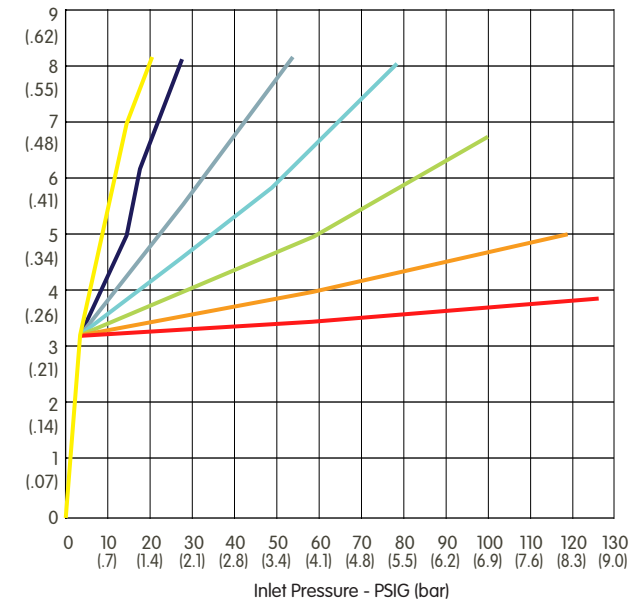

1800C and 1800C-HC Series Service Regulator Dimensions

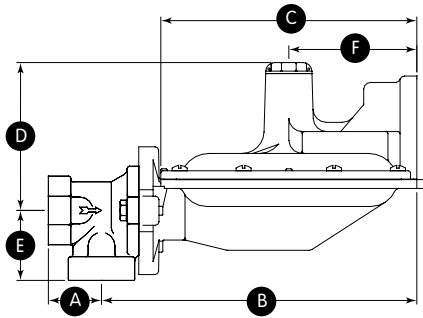

Model 1813C - 90°

Inlet	Outlet	A	B	C	D	E	F
3/4"	3/4"	1-9/16" 39.7mm	8-7/8" 225.4mm	7-1/4" 184.2mm	4-1/8" 104.8mm	2" 50.8mm	3-5/8" 92.1mm
3/4"	1"	1-9/16" 39.7mm	8-7/8" 225.4mm	7-1/4" 184.2mm	4-1/8" 104.8mm	2" 50.8mm	3-5/8" 92.1mm
1"	1"	1-9/16" 39.7mm	8-7/8" 225.4mm	7-1/4" 184.2mm	4-1/8" 104.8mm	2" 50.8mm	3-5/8" 92.1mm

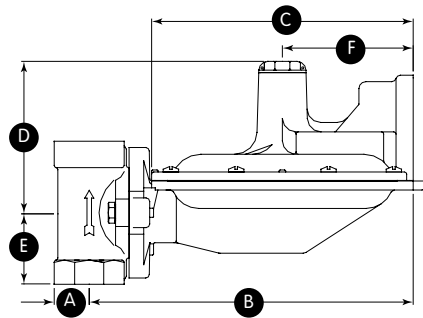

Model 1813C and 1813C-HC - 180°

Inlet	Outlet	A	B	C	D	E	F
3/4"	3/4"	1" 25.4mm	8-7/8" 225.4mm	7-1/4" 184.2mm	4-1/8" 104.8mm	2" 50.8mm	3-5/8" 92.1mm
3/4"	1"	1" 25.4mm	8-7/8" 225.4mm	7-1/4" 184.2mm	4-1/8" 104.8mm	2" 50.8mm	3-5/8" 92.1mm
1"	1"	1" 25.4mm	8-7/8" 225.4mm	7-1/4" 184.2mm	4-1/8" 104.8mm	2" 50.8mm	3-5/8" 92.1mm
1"	1-1/4"	1-1/8" 28.6mm	8-7/8" 225.4mm	7-1/4" 184.2mm	4-1/8" 104.8mm	2" 50.8mm	3-5/8" 92.1mm
1-1/4"	1-1/4"	1-1/8" 28.6mm	8-7/8" 225.4mm	7-1/4" 184.2mm	4-1/8" 104.8mm	2" 50.8mm	3-5/8" 92.1mm
3/4"	1-1/4"	1-1/8" 28.6mm	8-7/8" 225.4mm	7-1/4" 184.2mm	4-1/8" 104.8mm	2" 50.8mm	3-5/8" 92.1mm

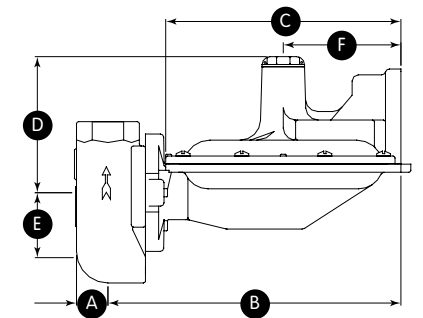

Model 1813C - Offset

Inlet	Outlet	A	B	C	D	E	F
3/4"	3/4"	1" 25.4mm	8-7/8" 225.4mm	7-1/4" 184.2mm	4-1/8" 104.8mm	2" 50.8mm	3-5/8" 92.1mm
3/4"	1"	1" 25.4mm	8-7/8" 225.4mm	7-1/4" 184.2mm	4-1/8" 104.8mm	2" 50.8mm	3-5/8" 92.1mm
1"	1"	1" 25.4mm	8-7/8" 225.4mm	7-1/4" 184.2mm	4-1/8" 104.8mm	2" 50.8mm	3-5/8" 92.1mm

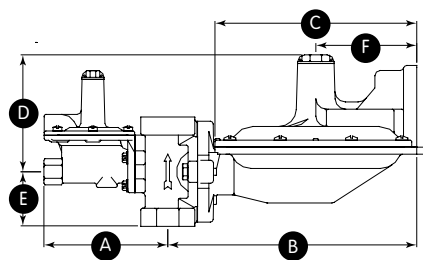

Model 1843C and 1843C-HC

Inlet	Outlet	A	B	C	D	E	F
3/4"	3/4"	4-1/2" 114.3mm	8-15/16" 227.0mm	7-1/4" 184.2mm	4-1/8" 104.8mm	2" 50.8mm	3-5/8" 92.1mm
3/4"	1"	4-1/2" 114.3mm	8-15/16" 227.0mm	7-1/4" 184.2mm	4-1/8" 104.8mm	2" 50.8mm	3-5/8" 92.1mm
1"	1"	4-1/2" 114.3mm	8-15/16" 227.0mm	7-1/4" 184.2mm	4-1/8" 104.8mm	2" 50.8mm	3-5/8" 92.1mm
1"	1-1/4"	4-1/2" 114.3mm	8-15/16" 227.0mm	7-1/4" 184.2mm	4-1/8" 104.8mm	2" 50.8mm	3-5/8" 92.1mm
1-1/4"	1-1/4"	4-1/2" 114.3mm	8-15/16" 227.0mm	7-1/4" 184.2mm	4-1/8" 104.8mm	2" 50.8mm	3-5/8" 92.1mm

Regulator Assembly Positions

180° Models

Valve Head Position "A"

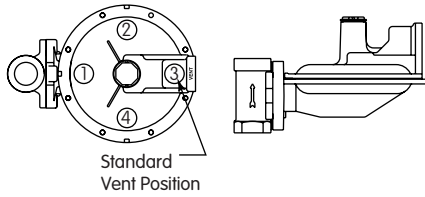

Valve Head Position "B"

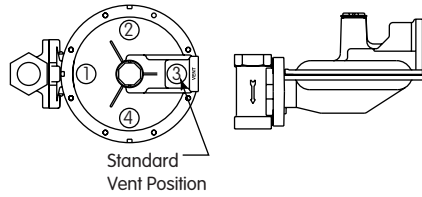

Valve Head Position "C"

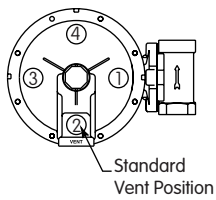

Valve Head Position "D"

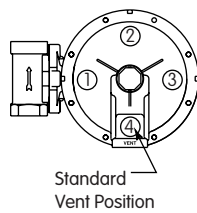

AC-250 Meter with 1813C Regulator

Example of Regulator Assembly Position

In the photo above the 1813C Regulator shown has an 180 degree valve head in Position "C" (Flow upward) with the vent in position 2 (Looking down). This would be assembly position C2.

90° Models

Valve Head Position "A"

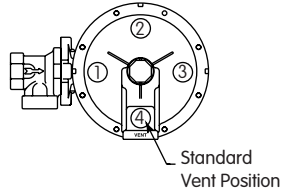

Valve Head Position "B"

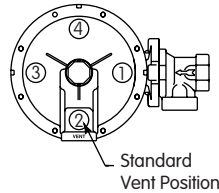

Valve Head Position "C"

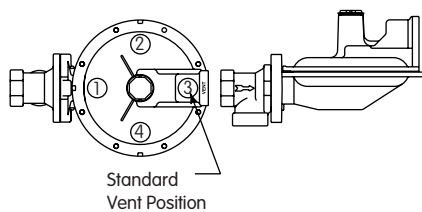

Valve Head Position "D"

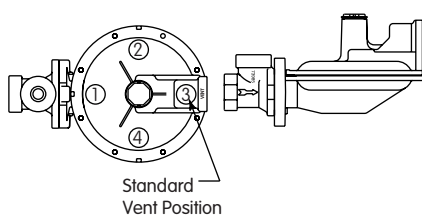

Ordering Information

- 1 Model number
- 2 Size of inlet and outlet
- 3 Inlet pressure, PSIG (bar)
- 4 Outlet pressure, inches w.c. (mbar) or PSIG (bar)
- 5 Flow, scfh (m3/h)
- 6 Kind and specific gravity of gas
- 7 Orifice size
- 8 Regulator assembly position number
- 9 Possible variation in inlet pressure for E.C. Orifice models
Maximum ___ PSIG (bar)
Minimum ___ PSIG (bar)

Offset Models

Valve Head Position "D"

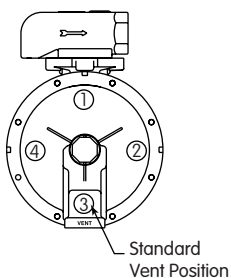

Shipping Weight

17.5 lbs/carton of four regulators

About Elster Group

A world leader in advanced metering infrastructure, integrated metering, and utilization solutions to the gas, electricity and water industries, Elster's systems and solutions reflect over 170 years of knowledge and experience in measuring precious resources and energy.

Elster provides solutions and advanced technologies to help utilities more easily, efficiently and reliably obtain and use advanced metering intelligence to improve customer service, enhance operational efficiency, and increase revenues. Elster's AMI solutions enable utilities to cost-effectively generate, deliver, manage, and conserve the life-essential resources of gas, electricity, and water.

Elster has over 7,500 staff and operations in 38 countries in North and South America, Europe, and Asia.

ISO 9001: 2000



Certificate No. 006697

Elster American Meter
2221 Industrial Road
Nebraska City, NE 68410
USA

T +1 402 873 8200
F +1 402 873 7616

www.elster-americanmeter.com

Elster Canadian Meter

T +1 519 650 1900
F +1 519 650 1917

www.elster-canadianmeter.com

© 2008 Elster American Meter. All rights reserved

Information contained herein is subject to change without notice. Product specifications may change. Contact your Elster American Meter representative for the most current product information. Printed in the United States.

EAM-TB8515.11-EN-P - June 2008
Supersedes EAM-TB8515.10-EN-P